

**Model: 7.3E 60 Hz**  
**6EF 50 Hz**

# KOHLER POWER SYSTEMS

**Gasoline**

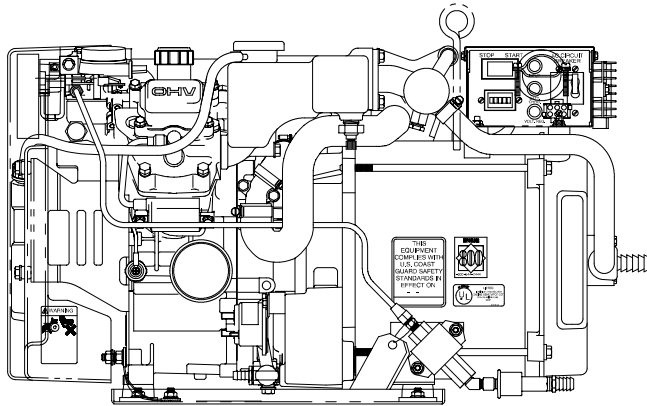

## Marine Generator Set

### Engine Features

- Gasoline powered
- Two cylinder
- Four cycle
- Heat exchanger
- Lifting eyes
- Fuel pump
- Fuel filter
- Closed cooling system
- Automatic choke
- Emission compliant

### Generator Features

- Remote connection availability
- Class H insulation
- 60/50 Hz capability
- Voltage regulation of  $\pm 2\%$
- Frequency regulation of  $\pm 5\%$
- RFI suppression
- Voltage adjustability
- Captive vibration isolation mounting system

### Optional Accessories

- Ship-to-shore transfer switch
- Seawater strainer
- Siphon break
- Sound shield

## Generator Weights and Dimensions

	Without Sound Shield	With Sound Shield
Weight, kg (lbs.)		
Wet		
7.3E	93 (205)	102 (224)
6EF	93 (205)	102 (224)
Dry		
7.3E	91 (200)	99 (219)
6EF	91 (200)	99 (219)
Length, mm (in.)	721 (28.37)	773 (30.44)
Width, mm (in.)	386 (15.21)	460 (18.10)
Height, mm (in.)	429 (16.87)	458 (18.02)

See the drawings on the last page for the detailed dimensions.

## Generator Ratings

Model Series	Voltage	Hz	25°C (77°F)	25°C (77°F)
			Amps	kW/kVA
7.3E	120	60	60.83	7.3/7.3
	120/240	60	30.42	7.3/7.3
6EF	110	50	54.55	6/6
	110/220	50	27.27	6/6
	220	50	27.27	6/6

RATINGS: Marine continuous ratings per ISO 3046, ISO 8528-1, and Kohler ISO rating guideline 2.14. Obtain technical information bulletin (TIB-101) on ratings guidelines for complete ratings definitions.

Availability is subject to change without notice. Kohler Co. reserves the right to change the design or specifications without notice and without any obligation or liability whatsoever. Contact your local Kohler generator distributor for availability.

# Application Data

## Engine

Engine Specifications	60 Hz	50 Hz
Manufacturer	Kawasaki	
Model	FD501D	
Type	4 Cycle	
Cylinders, number	2	
Displacement, L (CID)	0.4 (26.7)	
Bore and stroke, mm (in.)	67 (2.64) x 62 (2.44)	
Compression ratio	9.3:1	
Rated rpm	3600	3000
Max. power at rated rpm, HP	16	13.8
Cylinder block material	Aluminum	
Cylinder head material	Aluminum	
Piston rings	2 compression/1 oil control	
Crankshaft bearings, type	Insert	
Valve material	Steel alloy (JIS SUH3)	
Connecting rod material	Aluminum	
Governor, type	Gear driven centrifugal	

## Engine Electrical

Engine Electrical System	60 Hz	50 Hz
Ignition	Transistorized	
Starter motor	Bendix automotive type	
Spark plugs	Resistor-type RFI suppression	
Battery voltage (DC)	12	
Battery charging	15 amp	
Battery recommendation (min.)	260 CCA	

## Fuel

Fuel System	60 Hz	50 Hz
Type	Single-barrel, horizontal carburetor	
Choke	Automatic, electric	
Fuel pump	Electric	
Fuel pump, max. lift, m (ft.)	0.9 (3.0)	

Fuel Consumption	60 Hz	50 Hz
<b>Gasoline, Lph (gph) at % load</b>		
100%	3.56 (0.94)	3.03 (0.80)
75%	2.91 (0.77)	2.65 (0.70)
50%	2.38 (0.63)	1.93 (0.51)
25%	1.97 (0.52)	1.51 (0.40)

## Lubrication

Lubricating System	60 Hz	50 Hz
Type	Pressure	
Oil capacity with filter, L (qts.)	1.36 (1.44)	

## Cooling

Cooling System	60 Hz	50 Hz
L (qts.)	2.8 (3.0)	
Heat exchanger type	2.0 in. dia. x 1 pass cupronickel	
Seawater pump type	Direct-driven, 10-blade impeller	
Heat rejected to cooling water at rated kW, wet exhaust Btu/min.	547	465
Engine water pump flow, Lpm (gpm)	50.3 (13.3)	42.0 (11.1)
Seawater pump flow, Lpm (gpm)	28.8 (7.6)	24.1 (6.36)

## Operation Requirements

Air Requirements (Engine)	60 Hz	50 Hz
Engine combustion air requirements m <sup>3</sup> /min. (cfm)	0.7 (24)	0.6 (20)
Generator cooling requirements m <sup>3</sup> /min. (cfm)	2.6 (91)	2.1 (75)

## Engine Features

- Meets Coast Guard safety standards for electrical systems and gasoline fuel systems (33CFR183)
- One-side serviceability of fuel filter, cooling system, and lubrication system
- Low oil pressure cutout
- High water and high exhaust temperature cutouts
- Belt guard
- Disposable oil filter
- Oil drain valve
- Full-pressure lube
- Electronic fuel pump
- Antidieseling solenoid
- Solid-state ignition
- Integral 12-volt battery charger
- Attached overflow bottle

## Controller Features

- Start/stop switch
- Rubber mounts to isolate vibration
- Safety shutdowns:
  - Loss of coolant
  - High water temperature
  - Low oil pressure
- External 6-pin connector for remote panel harness
- Hourmeter for scheduling maintenance
- Starter interlock to prevent reengagement of starter whenever engine is running
- Plug/receptacle controller connections
- Terminal connections:
  - Clearly identified
  - Corrosion resistant
  - Eliminate the possibility of misconnection

# Application Data

## Generator Features

- Brushed, rotating field design permits power to be obtained from stationary leads.
- Rotor and stator are vacuum impregnated and coated with high-bond epoxy varnish. Varnish helps prevent corrosion in high-humidity areas.
- Rotors are dynamically balanced to minimize vibration.
- Copper windings ensure minimal heat buildup. Insulation meets NEMA standards for class H insulation.
- Directly connected to the engine, the generator has sealed precision ball bearings with a precision-machined steel sleeve in the end bracket (or end bearing tolerance ring) to prevent shaft misalignment and extend bearing life.
- Circuit breakers protect the generator from extreme overload.
- The generator is mounted on a drip-proof tray.
- The generator is equipped with a four-lead reconnectable stator.

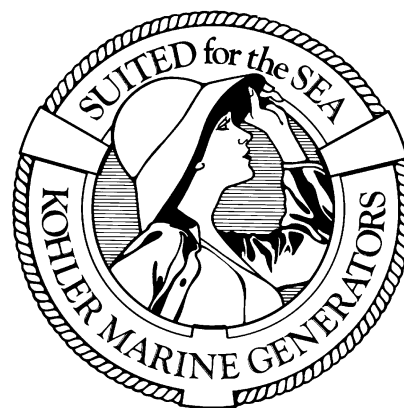

## Accessories

### Sound Shield

Provides for highly effective silencing, ease of access for engine/generator servicing, low maintenance, excellent durability, and safety.

### Siphon Break

Mandatory kit for generators installed below the waterline. Prevents the siphoning of flotation water into the engine.

### Ship-to-Shore Switch

The Kohler ship-to-shore transfer switch allows immediate switching to the Kohler® generator set power or shore power, protecting the electrical system from the possibility of simultaneous connection to both power sources.

### Remote Start Panel

Allows starting/stopping from a location remote from the generator set. Supplied with a 101 mm (4 in.) connection harness. The overall mounting dimensions are 128 mm (5.04 in.) by 70 mm (2.76 in.) with a minimum mounting depth of 57 mm (2 1/4 in.).

### Remote Start and Two-Meter Panel Kit

Allows starting/stopping from a location remote from the generator set. The illuminated gauges include an engine oil pressure gauge and water temperature gauge. The overall dimensions are 152 mm (6 in.) by 152 mm (6 in.) with a minimum mounting depth of 70 mm (2 3/4 in.). Requires remote connection/extension harness and sender kit.

### Remote Start and Four-Meter Panel Kit

Allows starting/stopping from a location remote from the generator set. The illuminated meters/gauges include a DC voltmeter, engine oil pressure gauge, water temperature gauge, and an hourmeter that records total generator set operating hours. Overall dimensions are 229 mm (9 in.) by 152 mm (6 in.) with a minimum mounting depth of 102 mm (4 in.). Requires remote connection/extension harness and sender kit.

### Sender Kit

Provides gauge senders for the remote start and two-meter panel kit and the remote start and four-meter panel kit. The gauge sender kit is required to make the oil pressure and water temperature gauges functional.

### Remote Connection/Extension Harness

Provides additional wiring between all remote panels and the controller connector. One required for each remote start and meter panel kit. Extension limited to a total of four kits and 23 m (75 ft.).

### 12-Inch Remote Wiring Harness

This 0.3 m (1 ft.) wiring harness has a 6-pin connector on one end which is keyed to the controller box connector. The other end has pigtailed for connection to a customer-supplied start switch, generator ON light, hourmeter, etc.

### Line Circuit Breakers

Protects generator from extreme overload.

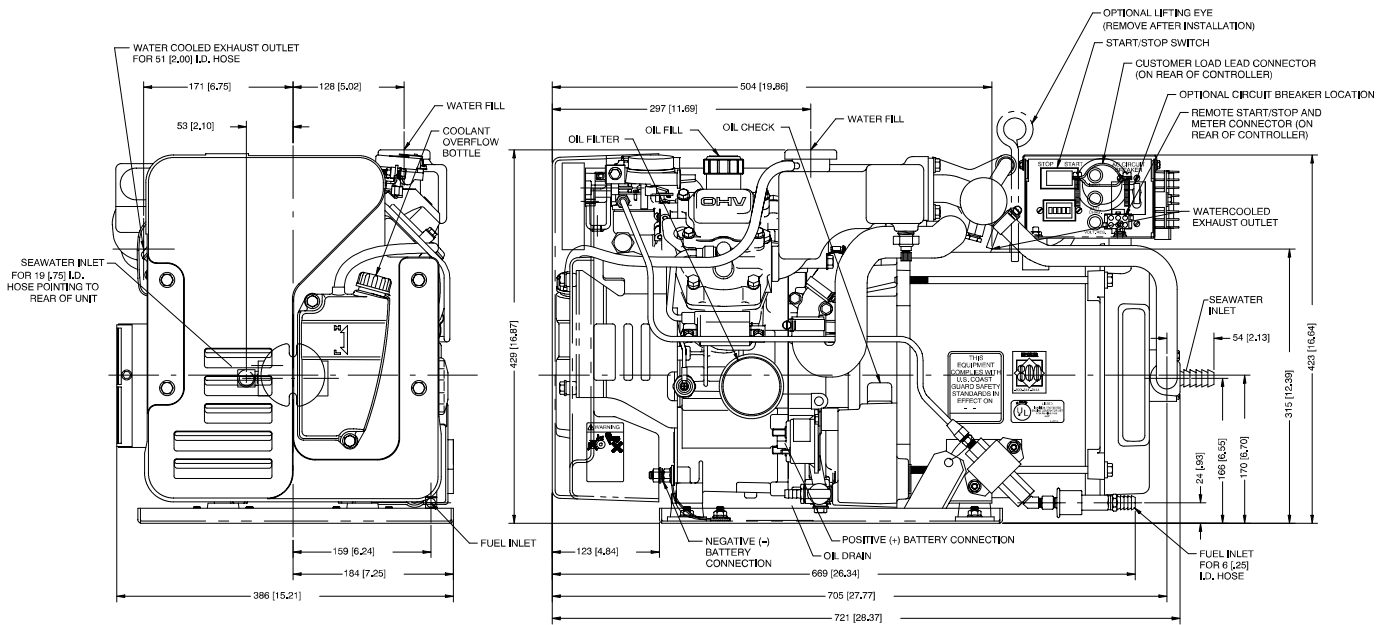

ADV-6395A-K

SIPHON BREAK CONNECTIONS FOR 16 [6,2] OR 19 [1,75] LD. HOSE

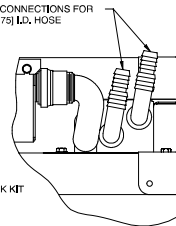

OPTIONAL SIPHON BREAK KIT

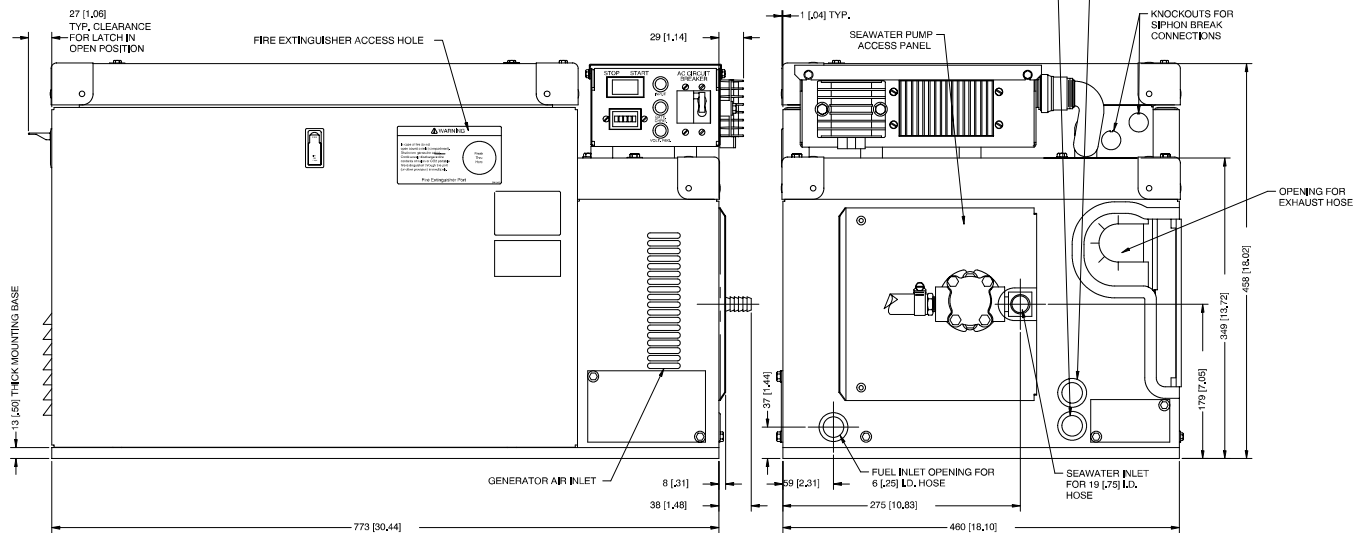

ADV-6395B-K

**DISTRIBUTED BY:**

NOTE: Dimensions in brackets are inch equivalents.

NOTE: This drawing is provided for reference only and is not intended for installation planning. Contact your local distributor for more detailed information.

© 1998, 1999, 2000, 2002, 2003 by Kohler Co. All rights reserved.